

the new
LAMBDA™ 750 UV/Vis/NIR
spectrophotometer
from PerkinElmer



high-performance system

delivering superior data quality for chemistry
and materials science applications

More accessories for maximum versatility

The LAMBDA 750 is designed to provide the maximum sampling flexibility for tough samples in chemistry, biochemistry and materials science. The system is ideal for a busy research or teaching laboratory, as accessories and detector modules can quickly and easily be interchanged to provide the optimum configuration for each measurement. For industrial applications, the design of the LAMBDA 750 and its accessories maximizes productivity through simple design which minimizes adjustment and maintains critical performance at the highest level.

Tackles difficult liquid samples with ease

- Turbid and cloudy liquids and suspensions, including DNA, proteins and blood are handled with ease by the sensitive LAMBDA 750, which can make highly accurate measurements up to 6 Absorbance units.
- A choice of cell-changers and autosamplers speed and simplify multi-sample analyses.
- A range of single and multi-cell Peltier accessories ensures precise and rapid thermostating for biological studies such as enzyme kinetics, DNA melt and general kinetics measurements in chemistry.



The PTP 6+6 Research Peltier system provides precise and rapid temperature control up to 100 °C, including multi-ramp programming.

- A huge choice of cells and sample holders allows virtually any liquid sample to be measured. Options include long-path cells, test-tube holders, flow-through cells and micro and semi-micro cells.

Powerful range of accessories simplifies analysis of solids

- Powder analysis is easily accomplished using the 60 mm integrating sphere – raw materials testing, organic and inorganic chemicals, geological and powdered polymers and coatings
- Specular, diffuse and total reflectance measurements using the 60 mm integrating sphere, allow rapid analysis of continuous solids such as glass, textiles, polymers and coated surfaces.
- A range of simple fixed and variable-angle solid sample holders allow transmittance measurements of materials such as glass, polymer films and filters.
- For relative and absolute reflectance measurements on mirrors, optics and thin-film coatings, choose from our range of easy-to-use, robust accessories, such as the fixed-angle V-N series and variable-angle options.



The 60 mm integrating sphere for reflectance and transmission measurements on solids and powders.

the LAMBDA 750:

accurate, reproducible,
results from your
toughest samples



PerkinElmer's LAMBDA™ UV/Vis/NIR and UV/Vis spectrophotometers have consistently offered best-in-class accuracy, precision and reproducibility to scientists for nearly 50 years. For sampling flexibility and superior data quality, our instruments have become the standard in thousands of laboratories, in industry and academia. We are pleased to introduce our newest addition to the LAMBDA series, the LAMBDA 750 and 750S models which were designed specifically for chemistry and materials science applications. The LAMBDA 750 and 750S provide an affordable system that is optimized for the analysis of tough liquid and solid samples in industry and academic labs.

The new LAMBDA 750 and 750S feature:

- True double-beam, double-monochromator design provides the highest possible stability coupled with the highest accuracy and lowest stray-light performance. This design has been proven by thousands of laboratories globally, running a wide range of samples.
- Extension of the measurement range into the Near-IR region of the spectrum provides richer and complementary spectral information for many compounds and materials.
- Unlike some competitive floor-mounted instruments, the LAMBDA 750 and 750S are designed to fit onto a standard bench-top, optimizing the use of space in your lab.
- Inexpensive to run – for example the twin deuterium and tungsten-halogen source lamps are pre-aligned for quick and easy replacement, and do not require a service visit.

LAMBDA 750

190nm

3300 nm

Transmission Detectors	Standard
60 mm Integrating Sphere	Optional
UV/Vis Resolution	0.17 – 5.00 nm
NIR Resolution	0.20 – 20.00 nm
Ideal Samples	Transmission of liquids, turbid liquids and solids
Typical Application Areas	<ul style="list-style-type: none"> • Inorganic and organic chemistry • Quality Control of raw materials and final products • Biological Sciences – DNA, Protein, Blood • Academia – teaching experiments • Materials Science

LAMBDA 750S

200nm

2500 nm

Transmission Detectors	Optional
60 mm Integrating Sphere	Standard
UV/Vis Resolution	0.17 – 5.00 nm
NIR Resolution	0.20 – 20.00 nm
Ideal Samples	Transmission, diffuse reflectance and total reflectance of solids and powders
Typical Application Areas	<ul style="list-style-type: none"> • Product and packaging appearance • Quality Control of raw materials and final products • Inorganic and organic chemistry • Materials science • Color measurements

inside the LAMBDA 750

rugged, proven technology
from the market leader

1
DEUTERIUM AND TUNGSTEN
HALOGEN LIGHT SOURCES
Prealigned and prefocused for
easy and quick replacement.

2
DOUBLE HOLOGRAPHIC
GRATING MONOCHROMATORS
For ultra-low stray light
performance, high accuracy
and high reproducibility.

3
COMMON BEAM MASK
Allows precise adjustment of the
beam height to match samples of
different dimensions.

4
COMMON BEAM DEPOLARIZER (optional)
Corrects for inherent instrument polarization
to allow accurate measurements of
birefringent samples.

5
CHOPPER
Switches between sample and reference beam.
Four-segment design provides individual blank
readings for sample and reference, increasing
measurement accuracy.

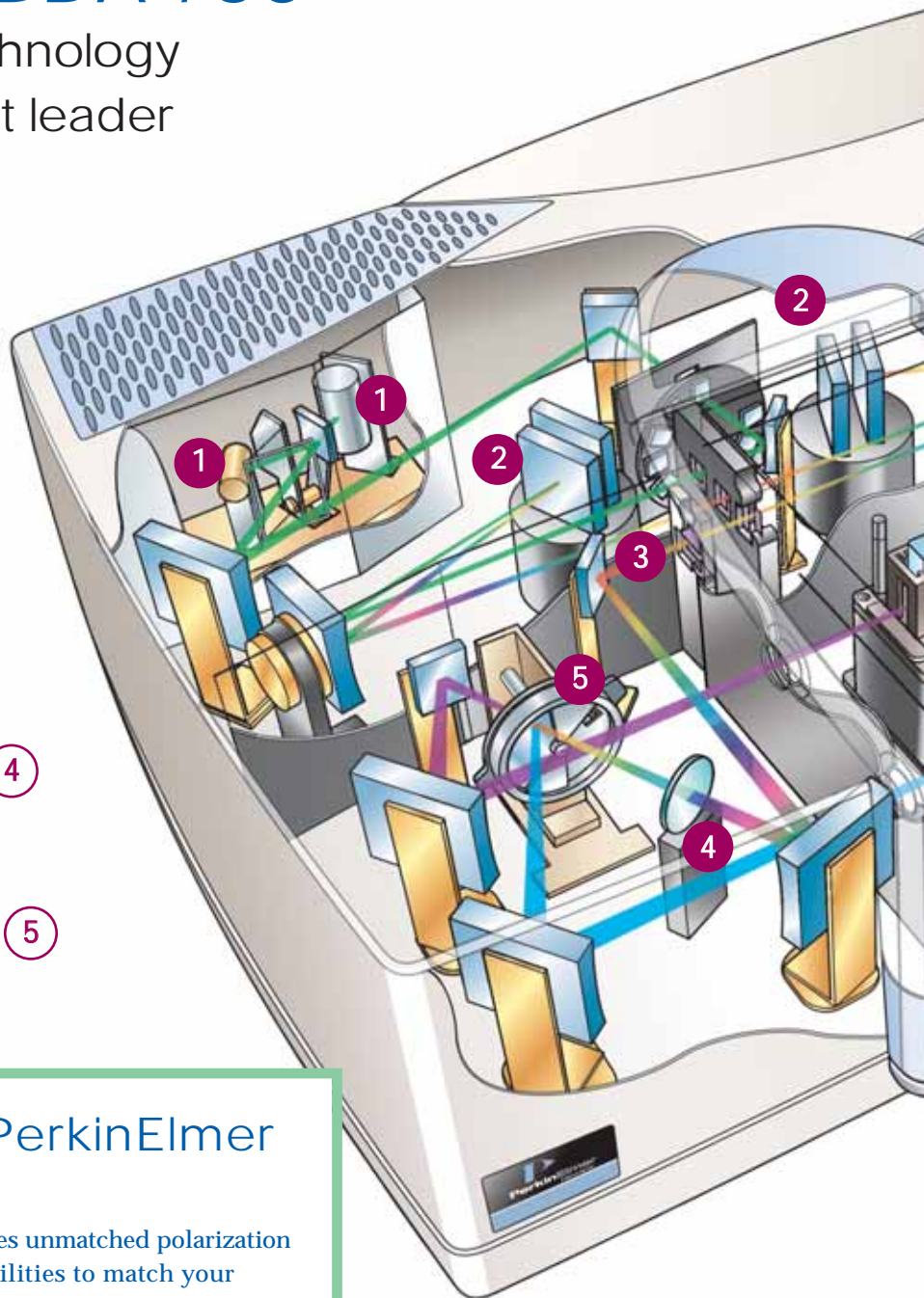

Another PerkinElmer exclusive

LAMBDA 750 features unmatched polarization
measurement capabilities to match your
analytical needs.

- Common beam depolarizer corrects for instrument bias.
- Automated polarizer/depolarizer drive in the large sample compartment provides further depolarization or allows study of oriented samples with polarized light.
- Compatible with transmission and reflectance measurements.

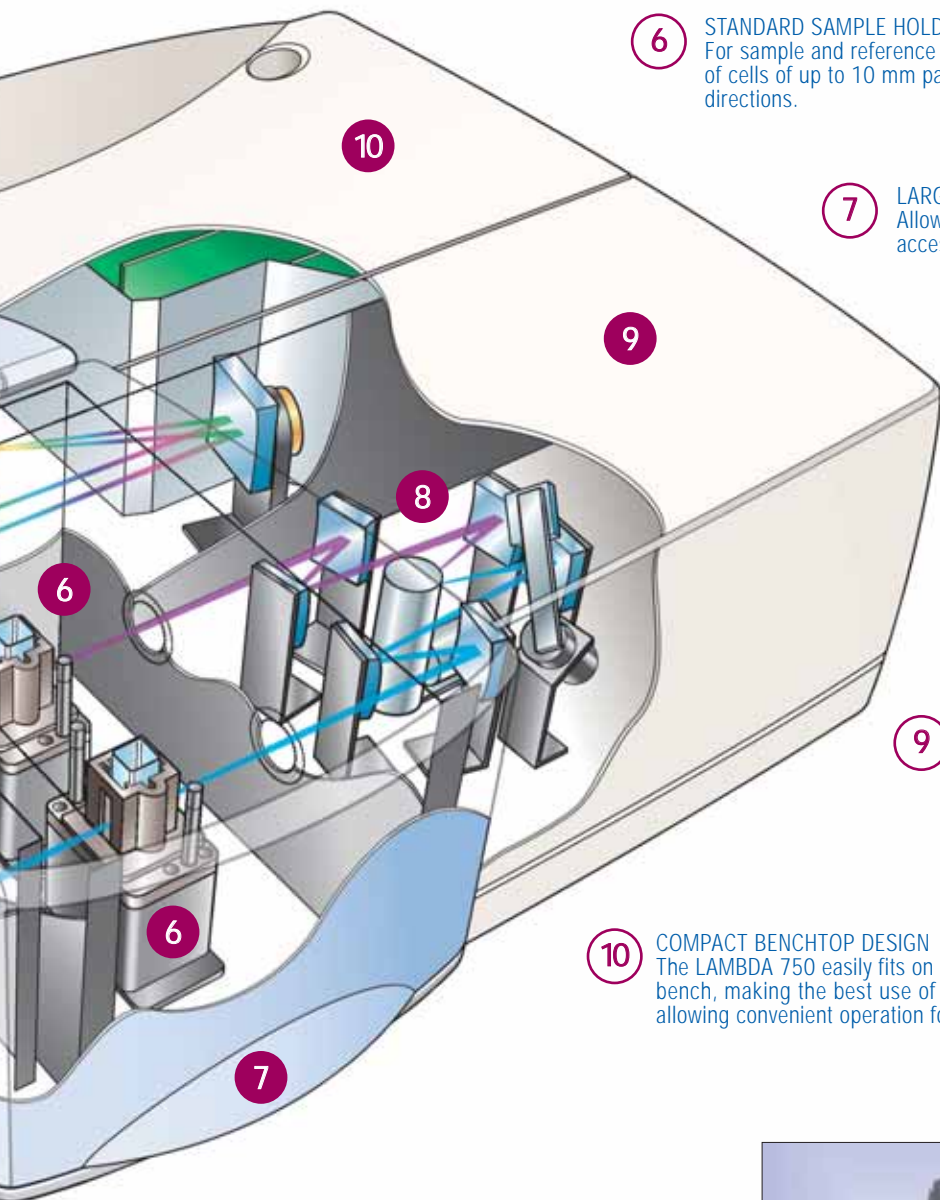

6 STANDARD SAMPLE HOLDERS
For sample and reference beam positions, accommodating a large selection of cells of up to 10 mm pathlength. Fully adjustable in vertical and horizontal directions.

7 LARGEST SAMPLE COMPARTMENT IN THE INDUSTRY
Allows easy access to a wide variety of sampling accessories and sample types.

8 HIGH-SENSITIVITY R928 PHOTOMULTIPLIER AND Peltier-COOLED PBS DETECTORS
Provides full range UV/Vis/NIR coverage from 190 to 3300 nm.

9 SECOND SAMPLING AREA
Houses a choice of snap-in sampling modules including transmission optics (shown) and the 60 mm integrating sphere. The linear optical path provides the highest accuracy and reproducibility for all integrating sphere measurements.

10 COMPACT BENCHTOP DESIGN
The LAMBDA 750 easily fits on a standard laboratory bench, making the best use of available space and allowing convenient operation for all users.

Twice the flexibility with two sampling compartments

Two large sample compartments accommodate virtually any sample or sampling accessory with ease. The primary compartment is used for a wide range of cell-holders, reflectance and transmission accessories, while the second can be configured with a choice of snap-in transmission detectors or 60 mm integrating sphere modules. Modules can be interchanged rapidly, making it easy to configure the system for optimum results for any sample type. There is also plenty of room for custom sample cells or accessories, if you have special experimental requirements.

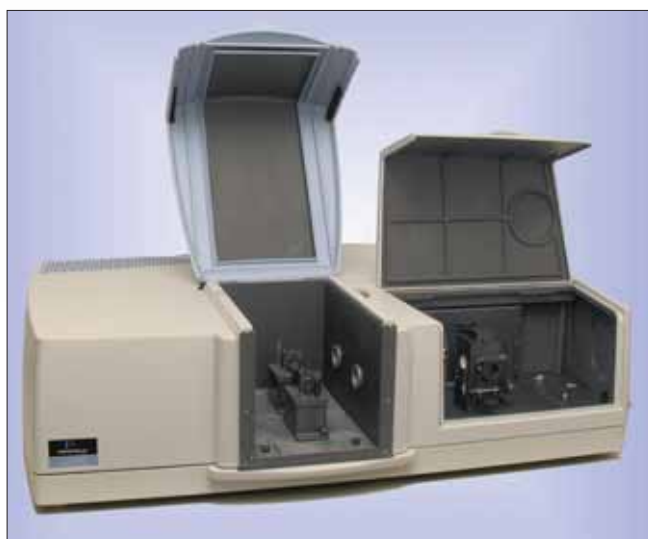

UV WinLab Software – powerful, flexible and secure

PerkinElmer’s powerful UV WinLab™ software helps you to be as productive as possible, guiding you through method development, analysis of results and reporting in a series of simple steps. UV WinLab software offers quick, intuitive instrument set-up, with all parameters and settings available at a glance, and a comprehensive range of data collection modes to provide maximum applications flexibility. Results are stored in a secure database, protecting valuable experimental data and enabling powerful search and trending functions to aid review and retrieval of results. For regulated industries, the software is also available in an Enhanced Security (ES) 21 CFR Part 11 compliant version.

Data Collection Mode	Ideal For
Wavelength Scan	Full or partial range spectral characterization
Quant and Scanning Quant	Quantitative Analysis on discrete peaks or full spectra
Time-Drive	Kinetics, including general and enzyme kinetics
Wavelength program	Rapid measurement at single or multiple discrete wavelengths

A full suite of data collection modes cater for virtually any application.

Thorough instrument performance validation UV WinLab contains a full-suite of over 20 instrument performance validation (IPV) tests to provide a convenient way to check and monitor the performance level of your LAMBDA 750.

PerkinElmer Life and Analytical Sciences
 710 Bridgeport Avenue
 Shelton, CT 06484-4794 USA
 Phone: (800) 762-4000 or
 (+1) 203-925-4602
www.perkinelmer.com

For a complete listing of our global offices, visit www.perkinelmer.com/lasoffices

©2007 PerkinElmer, Inc. All rights reserved. The PerkinElmer logo and design are registered trademarks of PerkinElmer, Inc. LAMBDA and WinLab are trademarks of PerkinElmer, Inc. or its subsidiaries, in the United States and other countries. All other trademarks not owned by PerkinElmer, Inc. or its subsidiaries that are depicted herein are the property of their respective owners. PerkinElmer reserves the right to change this document at any time without notice and disclaims liability for editorial, pictorial or typographical errors.

Powerful spectral processing

UV WinLab’s integral math engine enables raw data to be easily transformed into the final result. Processing is automatically saved as part of the method, allowing standard or frequently used calculations to be recalled rapidly each time they’re needed.

Applications-specific software modules

For a number of key application areas including glass and color methods, a range of software modules is available to allow deeper investigation of your sample using built-in industry standard protocols.

Application Expertise, Service and Support

Our extensive industry knowledge and depth of our support staff assures you of a rapid solution to any problem. PerkinElmer also offers technical and support services in more than 125 countries, with a team of over 1000 factory-trained service professionals.

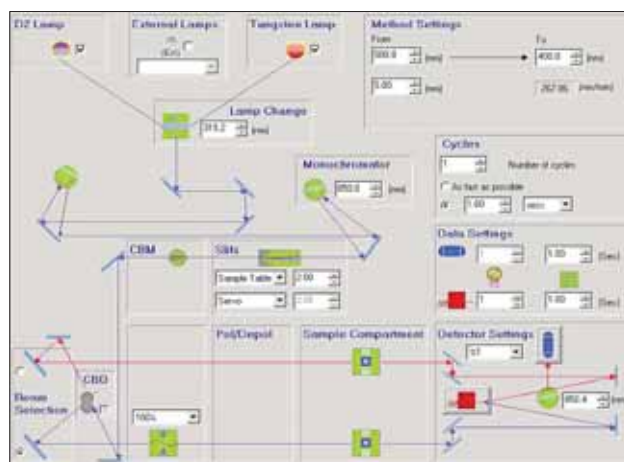

Simple and convenient instrument set-up.

